

# Building Backup-to-Disk and Disaster Recovery Solutions with the ReadyDATA™ 5200

Explosive data growth is a challenging reality for IT and data center managers. IDC reports that digital content will grow to 2.7 ZB in 2012, up almost 50 percent from 2011, on its way to 8 ZB by 2015. This growth is the result of many factors, including heavy use of mobile devices, which enables more data creation and more duplication, and increasing reliance on virtualization, among others.

More data to be stored means more data to protect, increasing demands on backup systems. If you're still relying on an inefficient, failure-prone tape-based backup system, these demands are magnified for you. Disk-based backup systems are faster and easier to manage, and provide unified architecture and better data integrity than tape-based systems. What's more, anyone designing a data protection solution faces a dizzying array of choices, especially when considering which backup software to implement.

But your choice of network storage is simple: The NETGEAR® ReadyDATA™ 5200. No matter which software backup vendor you choose, the ReadyDATA 5200 provides you with a cost-effective, easy-to-deploy, feature-rich repository for backup data.

The ReadyDATA 5200 supports industry-standard file-sharing protocols including iSCSI, CIFS, and NFS. It also offers high-end features that greatly enhance your data protection solution, including data deduplication, compression, cloud-managed site-to-site replication, high-efficiency data snapshots, and instant expansion.

Any backup software that you implement can leverage these features using standard interfaces and agents. With the ReadyDATA 5200, the process of backing up data and replicating backups off site for protection against disasters is simple:

1. Your third-party backup software writes backups directly to the ReadyDATA 5200 using standard network protocols.
2. Compress and deduplicate your data as it is written to the ReadyDATA 5200, saving space as data is written.
3. The ReadyDATA 5200 can take periodic snapshots upon completion of each backup volume.
4. Use replication to move both the backup data and snapshots to an offsite ReadyDATA 5200 for recovery in the event of a disaster.

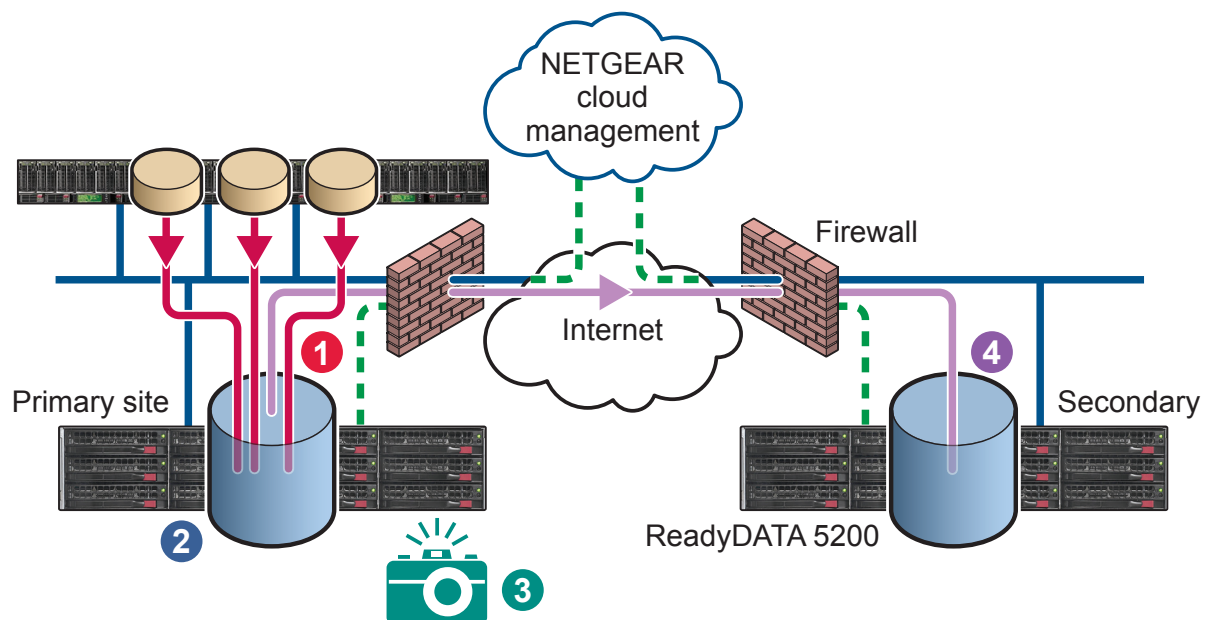

Figure 1. Backup and snapshot data moved off site for disaster recovery protection

Building your backup solution with the ReadyDATA 5200 provides simplicity and efficiencies that reduce costs. These technologies make the ReadyDATA 5200 ideal storage for backup solutions:

- **Data deduplication and compression:** Greatly reduces storage capacity requirements by shrinking backup data and removing globally common blocks of data as they are written to the ReadyDATA 5200. This technique is ideal for backup solutions that periodically create full backups because any data that is common to multiple backup jobs is written only once, thus providing capacity savings.

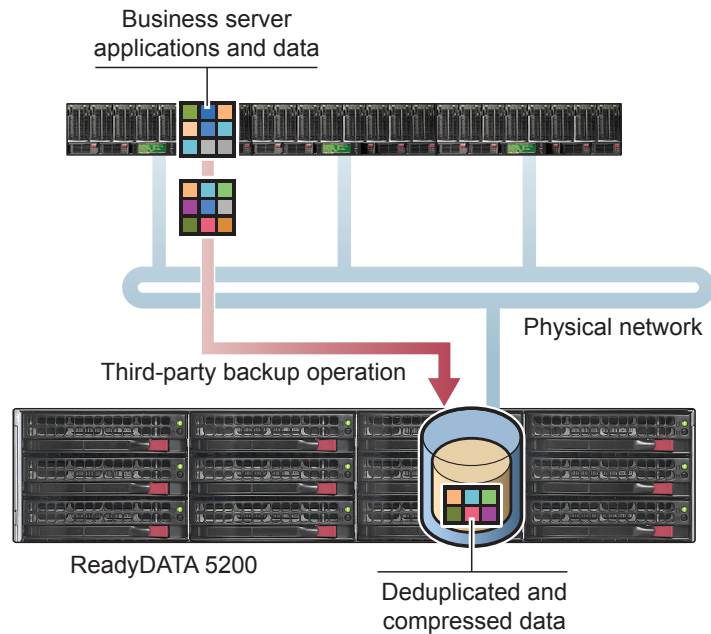

Figure 2. Data deduplication and compression

- **Cloud-managed constant block-level replication:** Provides the simplest way to get backup data off site in a timely manner. When replication is enabled between two ReadyDATA 5200 storage systems, data is sent from one system to another as it is written. This means backup data is being sent off site for disaster recovery protection at the same time that the primary backup job is running. Running the offsite operations in parallel greatly reduces the time that's required to complete backup jobs and offers better protection for your offsite data.

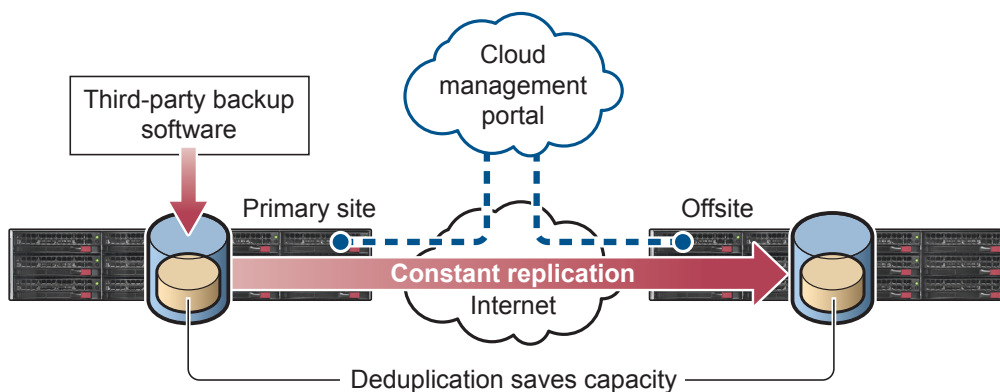

Figure 3. Cloud-managed block-level replication

- **High-efficiency data snapshots:** Provide the ability to roll back a ReadyDATA 5200 to a previous point in time. This technology is ideal for protecting against data loss due to corruption. If data becomes corrupt on the system due to software failure or malicious activity, quick recovery is seamless using the ReadyDATA 5200's snapshot time line. You can create a schedule to automatically create snapshots that provide granular fallback points.

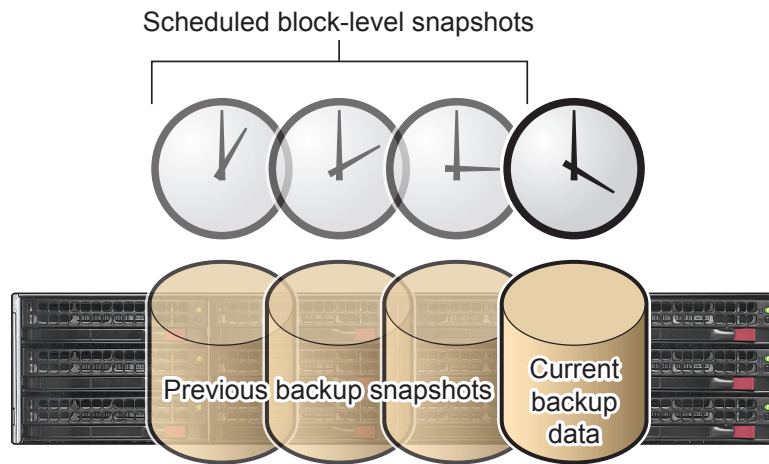

Figure 4. High-efficiency data snapshots

- **Instant expansion:** As data utilization grows, so does your backup storage requirement. The ReadyDATA 5200's instant expansion capability allows for large amounts of storage capacity expansion without downtime, wait time, or risk. You can add up to 48 drives in one operation without moving any data, meaning that scaling up your backup storage is hassle-free.

## BUILDING A COMPLETE BACKUP-TO-DISK OFFSITE SOLUTION

You must balance many considerations when building a backup-to-disk (B2D) offsite solution. Determining which backup software to use requires that you consider backup frequency, recovery methods, application integration, cost and much more.

Regardless of which backup software you choose, the ReadyDATA 5200 can provide the right storage capability. When you implement the ReadyDATA 5200 in your B2D solution, your need to ensure that your performance requirements are met so that backups can be completed within your backup window.

The speed of your system's network connection is a major factor affecting overall backup performance. Depending on the configuration you purchase, the ReadyDATA 5200 provides both 10 GbE and 1 GbE connectivity.

Interface	Potential Throughput
1 GbE	110 MB/s
10 GbE	1250 MB/s

**Note:** The ReadyDATA 5200's performance varies depending on the performance of the source systems that it is protecting. When using multiple physical interfaces, you can increase performance by running simultaneous backup jobs.

## VIRTUAL INTERFACES FOR BALANCING LOAD

In an environment where backup clients are slow, running simultaneous backup jobs from many clients to one ReadyDATA 5200 storage system can enhance performance. The ReadyDATA 5200 allows you to divide your 1 GbE or 10 GbE bandwidth with virtual adapters, so that you can make the most efficient use of your network.

You can bond multiple physical network interfaces on the ReadyDATA 5200 to act as fast, redundant connectivity. You can then assign virtual adaptors to physical interfaces or bonds to access the network. The ReadyDATA 5200 allows you to configure options independently for each virtual adaptor, including options for IP settings, VLAN tagging, jumbo frames, and even performance throttling.

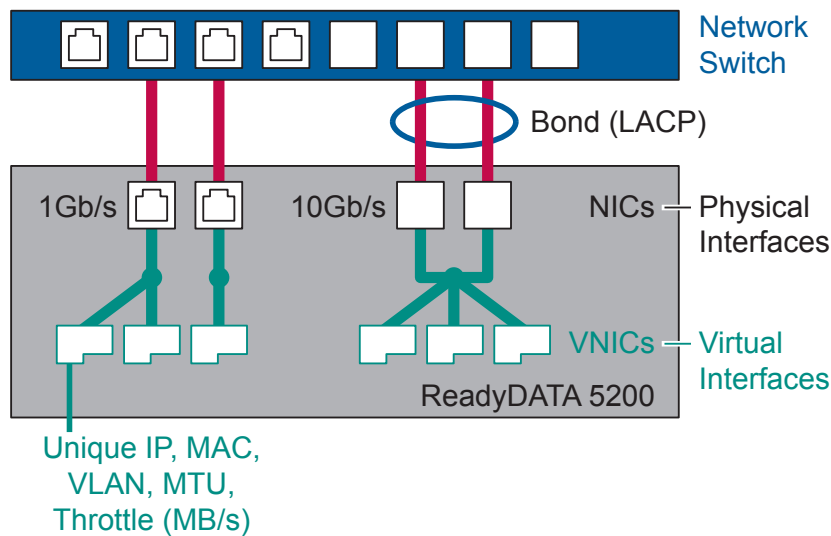

Figure 5. Virtual network interfaces

Virtualized networking enables the ReadyDATA 5200 to service many separate networks and allows you to control how much bandwidth is used for each storage-related task.

## WRITE THROUGHPUT PERFORMANCE

The most important performance metric to consider when designing a B2D solution is sequential write throughput. Throughput dictates the amount of data that can be written to a storage system during backup operations. You can use throughput metrics to calculate the amount of data that can be written within a backup window.

The following chart shows expected performance of write throughput based on number of drives.

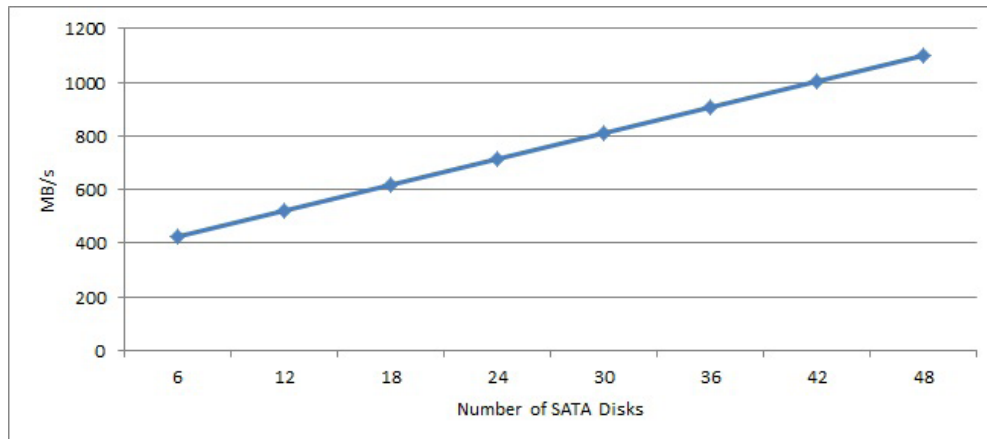

Figure 6. ReadyDATA 5200 SATA drive sustained throughput

**Note:** This benchmark was created using SATA drives on a ReadyDATA 5200. Use of SAS drives or SSDs enhances performance but is not ideal for backup-to-disk workloads due to the capacity constraints of SAS drives and SSDs.

## REPLICATION CONSIDERATIONS

To provide flexibility to meet your bandwidth constraints and recovery requirements, the ReadyDATA 5200 offers replication features that support a variety of configurations and network topologies.

Replication on the ReadyDATA 5200 allows periodic and constant replication between two or more ReadyDATA 5200 storage systems. You can locate the systems on a private LAN or separate them using the Internet. When data is replicated over the Internet, the ReadyDATA 5200 automatically encrypts it for secure transmission.

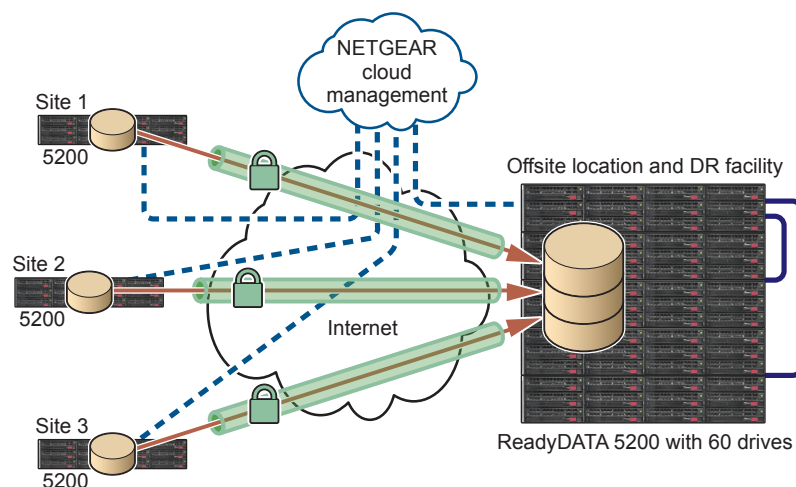

Figure 7. Replication over the Internet

This solution provides granularity by allowing individual shares or iSCSI LUNs to be replicated from one ReadyDATA 5200 system to another. This mirroring technology tracks blocks as they change and replicates incremental changes asynchronously from one ReadyDATA 5200 system to another.

Sending only block-level changes from one system to the next means that only changed data needs to be moved and that the performance requirements on both the source and destination systems are minimal.

Replication relationships can be configured as follows:

- **Constant replication:** Ideal for B2D, this configuration is driven by activity at the source storage system. Data is replicated to the destination device constantly. Whenever new blocks are written on the source storage system they are immediately sent to the destination source storage system. This is ideal in high-performance networks such as LAN environments or over fiber connections between locations. This option is ideal for B2D solutions because it moves backup data as it is being created, meaning that in the event of a disaster the most current data possible is in a secondary location.
- **Periodic replication:** Ideal for heavy production workloads, this configuration is driven by the clock. Data is replicated periodically every 15 minutes to 24 hours, based on how you configure your ReadyDATA 5200. This configuration collects changes that occur over the selected time period and replicates them in line with the replication schedule. This option saves bandwidth in environments where data is constantly being rewritten, such as virtualization or production database solutions.

## CONCLUSION

The ReadyDATA 5200 is a cost-effective, easy-to-deploy, feature-rich repository for backup data. It works with any third-party backup software to help you create a simple backup-to-disk data recovery solution. The ReadyDATA 5200 supports industry-standard file-sharing protocols including iSCSI, CIFS, and NFS, and offers high-end features that greatly enhance your data protection solution, including data deduplication, compression, cloud-managed site-to-site replication, high-efficiency data snapshots, and instant expansion.

For more information about the NETGEAR ReadyDATA 5200, visit <http://www.netgear.com> or contact a NETGEAR channel partner or sales representative.